

APA TRADEMARKS & GRADE STAMP ANATOMY

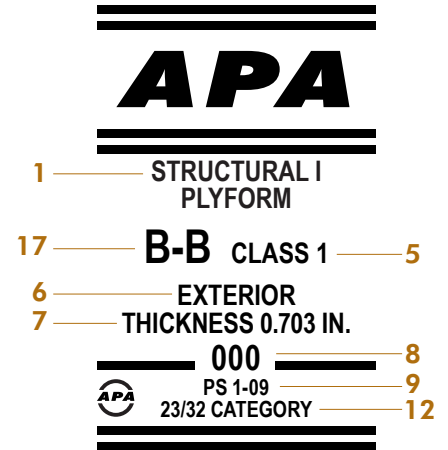
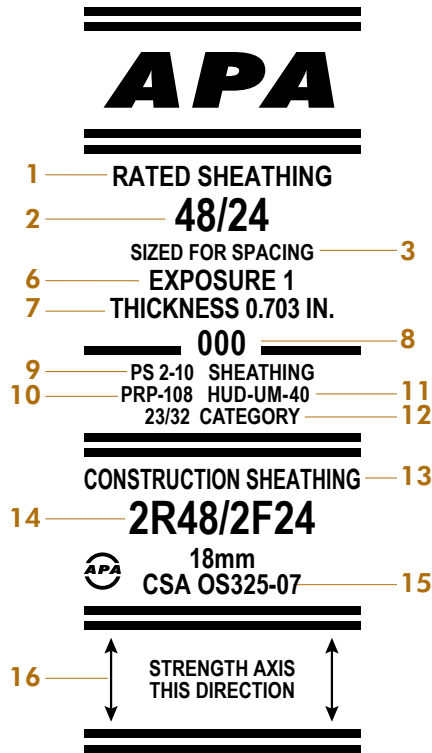
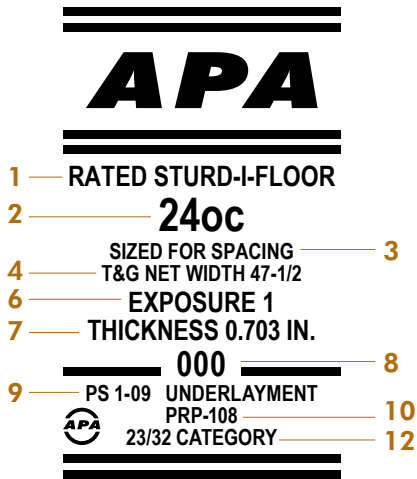

- | | |
|--|--|
| <ul style="list-style-type: none"> 1. Panel grade 2. Span Rating 3. Sized less than full length/width 4. Tongue-and-groove 5. Class of production 6. Bond classification 7. Decimal thickness designation (this value is generally at or near the lower tolerance specified in PS 1 or PS 2) 8. Mill number 9. Product Standard | <ul style="list-style-type: none"> 10. APA's Performance Rated Panel standard 11. HUD recognition 12. Performance Category 13. Panel grade, Canadian standard 14. Panel mark—Rating and end-use designation per the Canadian standard 15. Canadian Performance Rated Panel standard 16. Panel face grain orientation indicator 17. Face-back veneer grades |
|--|--|